

## Right Angle Connector\_3Pin\_2.5mm Pitch\_SMD Right Angle Series

### Basic Specification

**Part Number :** S-J-4015R20-3-25-0000  
**Rated Current :** 2A  
**Rated Voltage :** AC/DC12V  
**Contact Resistance :** 50mΩ MAX  
**Operation Temp. :** -40°C~+85°C  
**Cycle Durability:** 20,000cycles

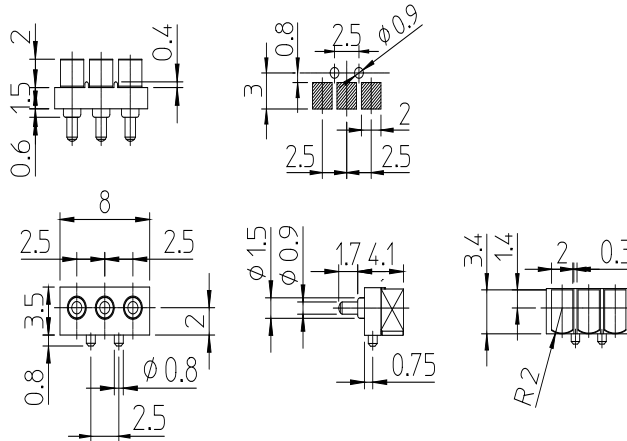

### Electrical Characteristic

**Rated Current :** AC/DC 12V 2A  
**Contact Resistance :** 50mΩ MAX  
**Insulation Resistance :** 100MΩ MIN  
**Dielectric Strength :** 3mA (MAX) leakage

### Mechanical Characteristics

**Pin Force :** 1.08N ± 0.25N  
**Pin Strength :** 9.8N force on pin from any direction for 1min.  
**Pin Pulling Force :** 4.9N force on a pin from axis direction for 1min.

### Other Characteristic

**Operational Durability :** 20,000cycles  
**Low Temp. Durability :** Store in temp. -40°C ± 3°C for 96 hours then ,leaves in the ambient temperature. for 1hour.

**High Temp. Durability :** Store in temp. +85°C ± 2°C for 96 hours then ,leaves in the ambient temperature. for 1hour.

**Humidity Durability :** Store in temp. +60°C ± 2°C with humidity of 90~95% for 96hours, then leave in the ambient temperature for 1hours.

**Temp. Cycle Test :** Cycle 5times (Table1. shows test condition for 1cycle) Leave in the ambient temp. for 1hour.

**Temp. And Humidity Cycle Test :** Operate cycle test 10times.(Fig1) Then leave in the ambient temp for 1hour. The other issues are in conformity to JIS C60068-2-38.

## Right Angle Connector\_3Pin\_2.5mm Pitch\_SMD Right Angle Series

### Other Characteristic

**Anti-corrosion(Salt Water Spray) :** The electrical performance shall be measured after continuous spray of salt water with  $5 \pm 1\%$  density and  $35 \pm 2^\circ\text{C}$  temperature for 48hours, cleaning with lukewarm water and dry, and leaving in ambient temperature for 1 hours.

**Vibration Test :** Connect each connector pin in series, conducting current of 0.1A. After that , the vibration described below is added.  
 \* Amplitude 1.5mm  
 \* Sweeping cycle 10~55~10Hz/minute  
 \* Duration of test: 2hrs for each of X,Y,Z axis.

**Shock Test :** Connect each connector pin in series, conducting current of 0.1A. After that , the shock described below is added.  
 \* Accelerating rate:  $490\text{m/s}^2$   
 \* Operating time of the test: 11ms  
 \* The number of operating times: 3shocks at X,Y,Z axis both In negative and positive direction.

**Heat Resistance :** The electrical performance shall be measured in ambient temperature after soldering in accordance with the reflow profile Fig 2.

**Table 1. Temperature Cycle**

Step	Temperature( $^\circ\text{C}$ )	Time(minites)
1	$-40 \pm 3$	30 - 35
2	5 - 35	10 - 15
3	$85 \pm 2$	30 - 35
4	5 - 35	10 - 15

**Fig 1. Temp. and Humidity Cycle**

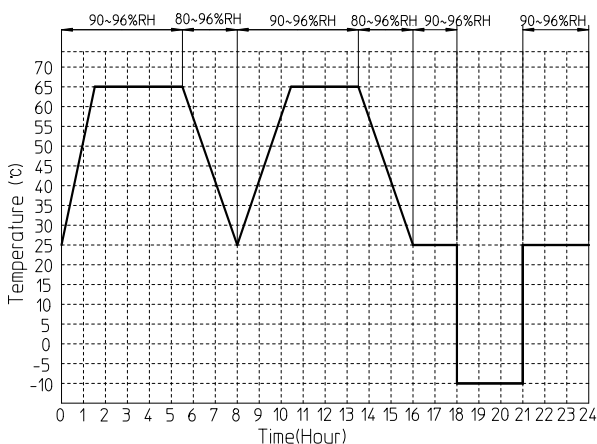

**Fig 2. Reflow Profile**

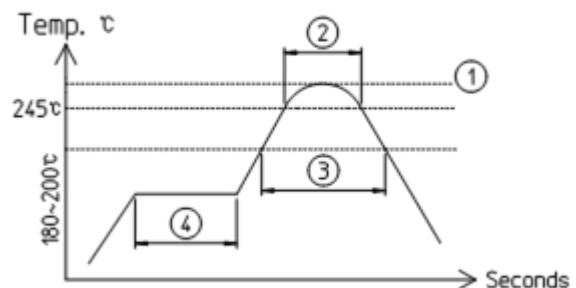

- ① MAX Temp :  $250^\circ\text{C}$
- ② Peak time ( $245^\circ\text{C}$ ) : 10sec MAX
- ③  $220^\circ\text{C}$  time : 80sec MAX
- ④  $190^\circ\text{C} \pm 10^\circ\text{C}$  time : 120sec.  $\pm 30\text{sec}$

- The specifications shown in this catalogue are subject to change without notice.
- Storage conditions: 35days max in room temperature