

Yokowo SPRING LOADED CONNECTOR

Pogo Pin Connectors_2Pin_3.5mm Pitch_SMD Vertical Series

Basic Specification

Part Number : S-J-3614B-2-35-0000
Rated Current : AC/DC 12V 2A
Contact Resistance: 50mΩ MAX
Operation Temp. : -40°C~+85°C
Cycle Durability: 20,000cycles

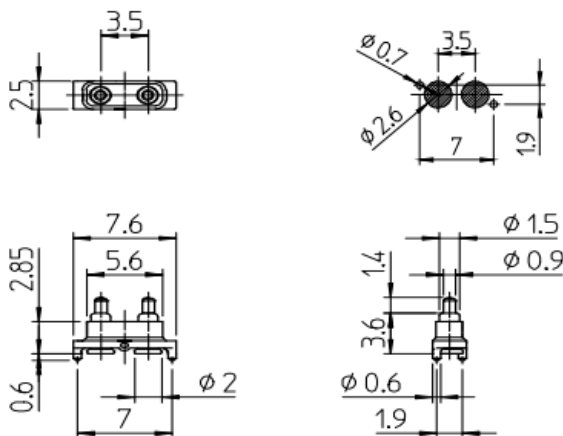

Electrical Characteristic

Rated Current : AC/DC 12V 2A
Contact Resistance : 50mΩ MAX
Insulation Resistance : 100MΩ MIN
Dielectric Strength : 3mA (MAX) leakage

Mechanical Characteristics

Pin Force : 1.08N ± 0.25N
Pin Strength : 9.8N force on pin from any direction for 1min.
Pin Pulling Force : 4.9N force on a pin from axis direction for 1min.

Other Characteristic

Operational Durability : 20,000cycles
Low Temp. Durability : Store in temp. -40°C ± 3°C for 96hours then ,leaves in the ambient temperature. for 1hour.

High Temp. Durability : Store in temp. +85°C ± 2°C for 96hours then ,leaves in the ambient temperature. for 1hour.

Humidity Durability : Store in temp. +60°C ± 2°C with humidity of 90~95% for 96hours, then leave in the ambient temperature for 1hours.

Temp. Cycle Test : Cycle 5times (Table1. shows test condition for 1cycle) Leave in the ambient temp. for 1hour.

Temp. And Humidity Cycle Test : Operate cycle test 10times.(Fig1) Then leave in the ambient temp for 1hour. The other issues are in conformity to JIS C60068-2-38.

Pogo Pin Connectors_2Pin_3.5mm Pitch_SMD Vertical Series

Other Characteristic

Anti-corrosion(Salt Water Spray) : The electrical performance shall be measured after continuous spray of salt water with $5 \pm 1\%$ density and $35 \pm 2^\circ\text{C}$ temperature for 48hours, cleaning with lukewarm water and dry, and leaving in ambient temperature for 1hours.

Vibration Test : Connect each connector pin in series, conducting current of 0.1A.
After that , the vibration described below is added.
* Amplitude 1.5mm
* Sweeping cycle 10~55~10Hz/minute
* Duration of test: 2hrs for each of X,Y,Z axis.

Shock Test : Connect each connector pin in series, conducting current of 0.1A.
After that , the shock described below is added.
* Accelerating rate: 490m/s^2
* Operating time of the test: 11ms
* The number of operating times: 3shocks at X,Y,Z axis both In negative and positive direction.

Heat Resistance : The electrical performance shall be measured in ambient temperature after soldering in accordance with the reflow profile Fig 2.

Table 1. Temperature Cycle

Step	Temperature($^\circ\text{C}$)	Time(minites)
1	-40 ± 3	30 - 35
2	5 - 35	10 - 15
3	85 ± 2	30 - 35
4	5 - 35	10 - 15

Fig 1. Temp. and Humidity Cycle

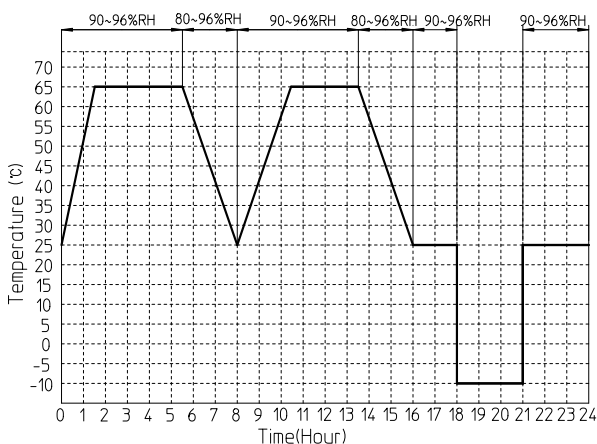
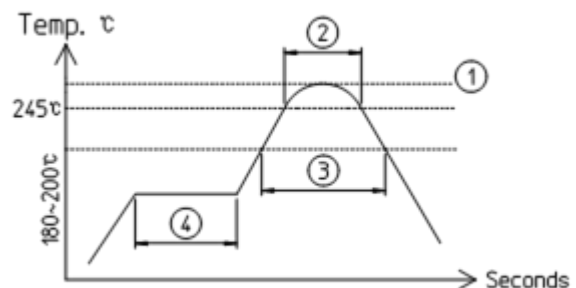

Fig 2. Reflow Profile



- ① MAX Temp : 250°C
- ② Peak time [245°C] : 10sec MAX
- ③ 220°C time : 80sec MAX
- ④ 190°C ± 10°C time : 120sec. ± 30sec

- The specifications shown in this catalogue are subject to change without notice.
- Storage conditions: 35days max in room temperature