

Yokowo SPRING LOADED CONNECTOR

J Series: 1-pin Low spring pressure series

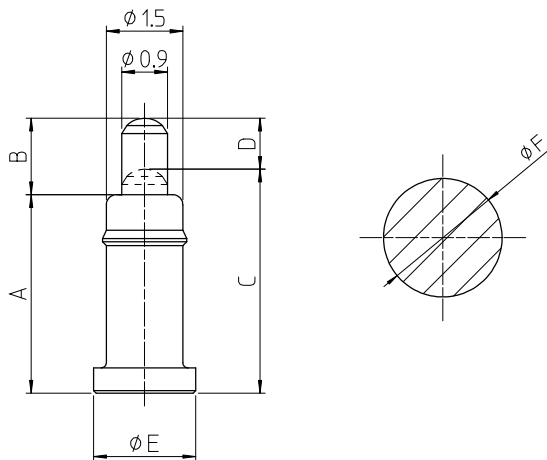

Basic Specifications

Rated Current : 0.5A
Rated Voltage : AC/DC 12V
Contact Resistance: 200mΩmax
Operation Temp. : -40°C~+85°C
Pin Force : 9.8N on a pin from any direction
Cycle Durability: 20,000 times

Type	Working Height(mm)	Reference Working Range (mm)	Spring Force	Rated Current	Dim.						Part Number
					A	B	C	D	E	F	
2307	2.5	(2.4 - 2.65)	0.3N	2A	2.3	0.7	2.5	0.5	1.8	2.4	J-2307PL-I-00-0000
2509	2.8	(2.6 - 2.95)	0.3N	2A	2.5	0.9	2.8	0.6	1.8	2.4	J-2509PL-I-00-0000
2809	3.1	(2.9 - 3.25)	0.3N	2A	2.8	0.9	3.1	0.6	1.8	2.4	J-2809PL-I-00-0000
2910	3.2	(3.0 - 3.4)	0.3N	2A	2.9	1.0	3.2	0.7	1.8	2.4	J-2910PL-I-00-0000
3111	3.4	(3.2 - 3.65)	0.3N	2A	3.1	1.1	3.4	0.8	1.8	2.4	J-3111PL-I-00-0000
3212	3.5	(3.3 - 3.8)	0.3N	2A	3.2	1.2	3.5	0.9	1.8	2.4	J-3212PL-I-00-0000
3413	3.8	(3.5 - 4.05)	0.3N	2A	3.4	1.3	3.8	0.9	2.0	2.6	J-3413PL-I-00-0000
3614	4.0	(3.7 - 4.3)	0.3N	2A	3.6	1.4	4.0	1.0	2.0	2.6	J-3614PL-I-00-0000
3915	4.4	(4.0 - 4.65)	0.3N	2A	3.9	1.5	4.4	1.0	2.0	2.6	J-3915PL-I-00-0000
4215	4.7	(4.3 - 4.95)	0.3N	2A	4.2	1.5	4.7	1.0	2.5	3.1	J-4215PL-I-00-0000
4617	5.2	(4.7 - 5.45)	0.3N	2A	4.6	1.7	5.2	1.1	2.5	3.1	J-4617PL-I-00-0000
5117	5.7	(5.2 - 5.95)	0.3N	2A	5.1	1.7	5.7	1.1	2.5	3.1	J-5117PL-I-00-0000
5517	6.1	(5.6 - 6.35)	0.3N	2A	5.5	2.0	6.1	1.1	2.5	3.1	J-5517PL-I-00-0000
5920	6.6	(6.0 - 6.9)	0.3N	2A	5.9	2.0	6.6	1.3	2.5	3.1	J-5920PL-I-00-0000
6220	6.9	(6.3 - 7.2)	0.3N	2A	6.2	2.0	6.9	1.3	2.5	3.1	J-6220PL-I-00-0000
6520	7.2	(6.6 - 7.5)	0.3N	2A	6.5	2.0	7.2	1.3	2.5	3.1	J-6520PL-I-00-0000
7025	7.8	(7.1 - 8.25)	0.3N	2A	7.0	2.5	7.8	1.7	2.5	3.1	J-7025PL-I-00-0000
7525	8.3	(7.6 - 8.75)	0.3N	2A	7.5	2.5	8.3	1.7	2.5	3.1	J-7575PL-I-00-0000

Electrical Characteristic

Rated Current : AC/DC 12V 2A
Contact Resistance : 200mΩ

Mechanical Characteristics

Pin Force: 0.3N ± 0.2N (See Above Table)
Pin Strength : 9.8N force on pin from any direction for 1min.

Other Characteristic

Operational Durability : 20,000 cycles
Low Temp. Durability : Store in temp. -40°C ± 3°C for 96 hours
then ,leaves in ambient temp. for 1 hour
High Temp. Durability: Store in temp. +85°C ± 2°C for 96 hours
then ,leaves in ambient temp. for 1 hour
Humidity Durability : Store in temp. +60°C ± 2°C with humidity of 90~95% for 96 hours

Yokowo SPRING LOADED CONNECTOR

Other Characteristic

Temp. Cyclic Test : Cycle 5 times (Table 1. shows test condition for 1 cycle)
Leave in ambient temp. for 1 hour.

Temp. And Humidity Cyclic Test: 10 times of a cycle test based on JIS C60068-2-38

Anti-corrosion (Salt Water Spray) : The electrical performance shall be measured after continuous spray of salt water with $5 \pm 1\%$ density and $35 \pm 2^\circ\text{C}$ temp. for 48 hours, cleaning with lukewarm water and dry, and leaving in ambient temperature for 1 hours

Vibration Test : Connect each connector pin in series, conducting current of 0.1A. After that the vibration described below is added.
 * Amplitude 1.5mm
 * Sweeping cycle 10~55~10Hz/minute,
 * Duration of test: 2hours for each of X,Y,Z axis

Shock Test : Connect each connector pin in series, conducting current of 0.1A. After that, the shock described below is added.
 * Accelerating rate: 490m/s^2
 * Operating time of the test: 1 ms
 * The number of operating times: *3shocks at C,Y,Z axis both.
 *In negative and positive direction.

Heat resistance : The electrical performance shall be measured in ambient temperature after soldering in accordance with the reflow profile Fig 2.

- The specifications shown in this catalogue are subject to change without notice.
- Storage conditions: 35days max in room temperature

Table 1. Temperature Cycle

Step	Temperature($^\circ\text{C}$)	Time(minites)
1	-40 ± 3	30 - 35
2	5 - 35	5 - 15
3	85 ± 2	30 - 35
4	5 - 35	5 - 15

Fig 1. Temp. and Humidity Cycle

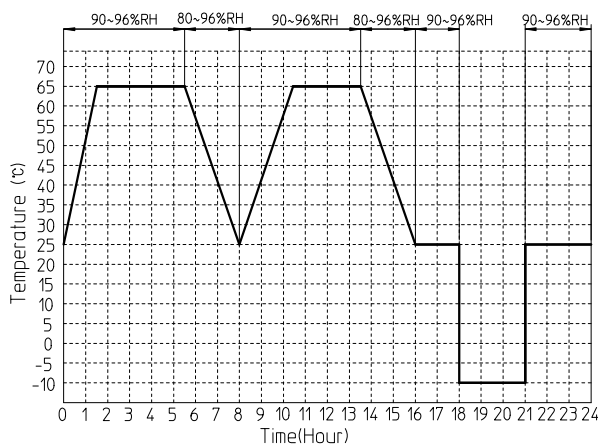
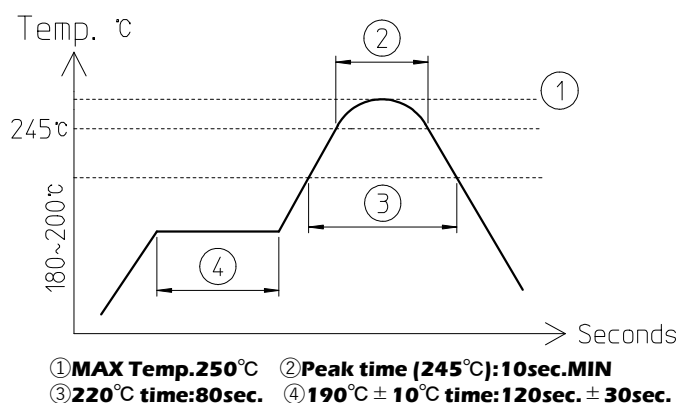

Fig 2. Reflow Profile



Yokowo SPRING LOADED CONNECTOR

Product Guide Line

Working Height Tolerance (in the direction of pin stroke)

The recommended working height, into which the pin is compressed, is as follows.

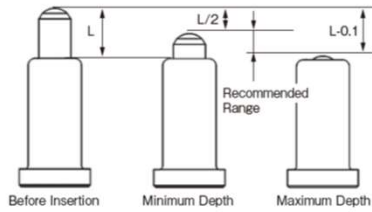

Minimum Depth

Be sure to insert more than half of the projecting portion (L mm). If it is not inserted deeply enough, the contact resistance may be unstable.

Maximum Depth

Be careful not to over insert the pin. The shoulder portion of the tube may become damaged, and cause the pin to not decompress.

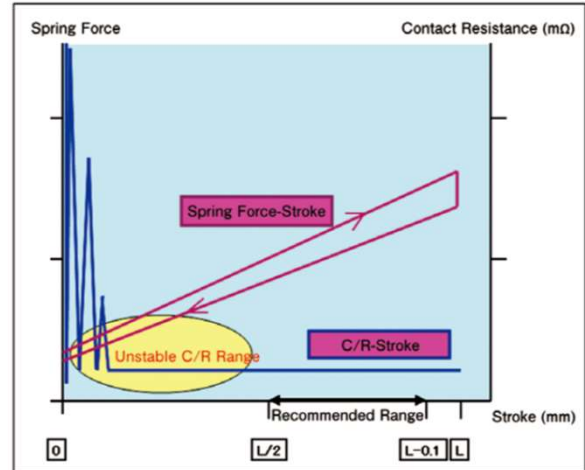
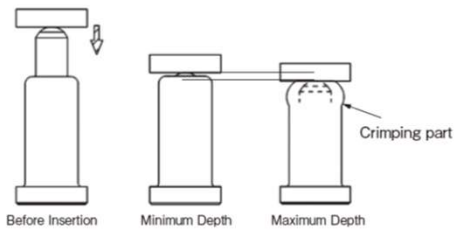

Recommended Land Pattern

The specifications of the recommended land pattern are as follows.

Recommended Land Pattern

Leave sufficient space to permit solder fillet formation, so soldering strength will be secured.

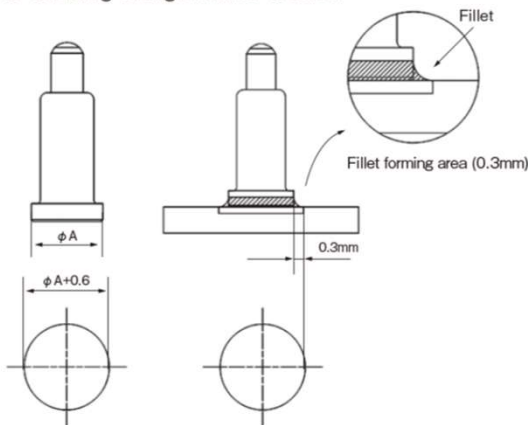

Solder Paste Thickness

The co-planarity of the product is max. 0.1. Make sure that the solder paste thickness is at least 0.1mm.

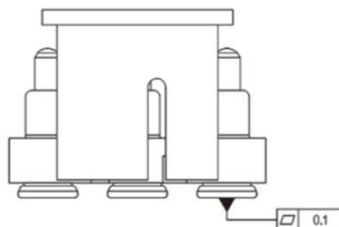

Mounting Area

The product comes with pick and place caps. Please be sure to spare mounting area wide enough to fit the outlines of the caps. This will be needed in order to permit removal of caps, and to prevent interference between parts that align next to each other.

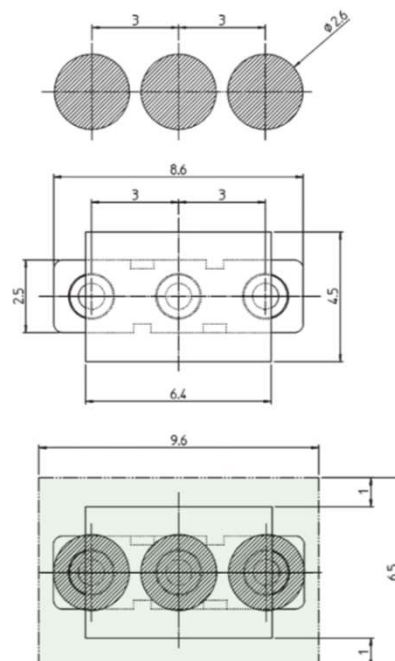

Yokowo SPRING LOADED CONNECTOR

Product Guide Line

Counterpart Terminal (Female Side Connector)

The recommended counterpart terminal is described below.

Outline of Counterpart Terminal

Be sure to use a counterpart terminal that is $\phi 2\text{mm}$ or larger, in order to consider the misalignment of contacts, mounting misalignment, and misalignment after mating.

Misalignment of Contacts = Product's Pitch Tolerance (0.1mm) + Pin Deflection (0.2mm) + Part's Tolerance (0.05mm)

Mounting Misalignment = 0.3mm

Misalignment after Mating = 0.3mm

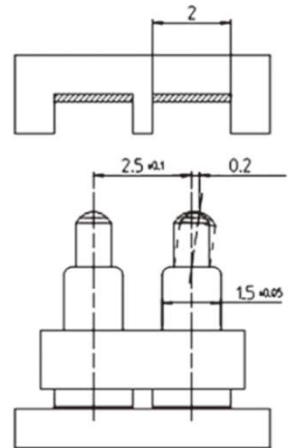

Materials, Roughness, and Hardness of the Counterpart Terminal

The recommended material of the counterpart terminal is brass plate, copper alloy plate, or substrate. The contact surface must be flat, smooth, and gold-plated.

Plating for the Counterpart Terminal

The recommended plating for the counterpart terminal is "Gold plating of at least $1\mu\text{m}$ over Nickel underplate," which is equivalent to the plating applied for pins of SPC products.

How to Mate the Pin with the Counterpart Terminal

Please note the following when mating the SPC with counterpart terminal.

Method of Fitting

Be sure to fit the pin into the counterpart terminal vertically.

If fitting from the lateral side of the SPC, the SPC may become deformed and cause poor contact resistance.

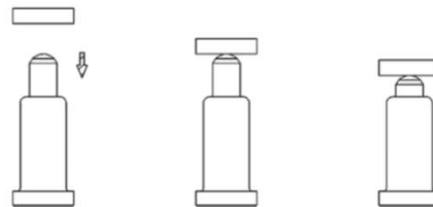

When fitting from an oblique angle, make sure that the angle between the two is smaller than 15 degrees at the time of contact. Be sure not to repeat mating more than 2,000 times in this way.

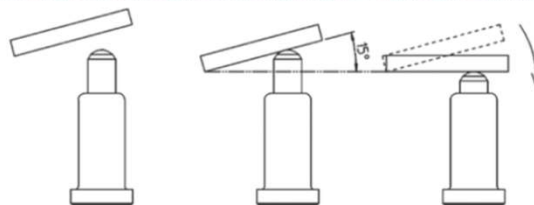

Do not slide the counterpart terminal on the pin. The plating on the top end of the pin may scratch off, and this will lead to poor contact resistance.

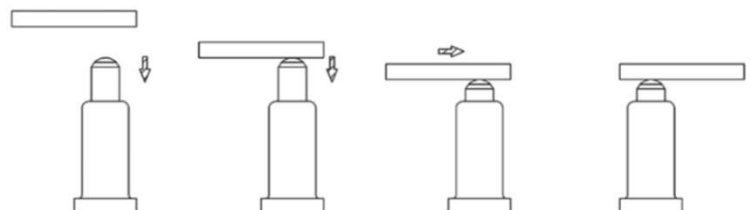

Allowable Angle with the Counterpart Terminal

Be sure to keep the angle between the counterpart terminal and SPC from 85 degrees to 95 degrees (within the range of ± 5 degrees vertically).

